



PBM-2236

PIPE BENDING MACHINE

Robust and safe for the operator
Wide bending range
PTO available for mandrel feeding
Wheel or rubber chain
Equipped with winch for Pipe Handling
Polyurethane lined bending sets available
TIER IV engine option available on request



PIPELINE SOLUTIONS



BASIC MACHINE DATA

ENGINE

Model	Yanmar 4TNV98
Net Flywheel power	47,5 kW
Governed speed	2300 rpm
Displacement	4 in line cylinder

REFILL CAPACITIES

Fuel tank	150 L
Hydraulic oil tank	200 L

HYDRAULIC SYSTEM

Maximum oil flow	72 liters/min
Pump pressure max	200 bar
Pump type	Variable axial piston pump load-sensing (option)

HYDRAULIC CYLINDERS

Outboard cylinder	2x
Inboard cylinder	4x
Wedge cylinder	1x
Clamp cylinder	1x

UNDERCARRIAGE

Track rollers/carrier rollers	4/1
Track shoes standard	500 mm

WINCH

Model	hydraulic worm gear winch
Maximum operating pressure	200 bar
Maximum feed flow rate	60 lt/min
Rated line pull	4500 kg
Cable length	16 m
Cable diameter	11 mm
Maximum Speed	9,4 mt/min

AUXILIARIES

Hydraulic PTO for mandrel	quick connect coupling 1/2"
---------------------------	-----------------------------



Hydraulic or pneumatic mandrels

In addition to the full range of pipe bending machines, EPE offers dedicated Hydraulic mandrels to optimize bending operation in case of light wall thicknesses, avoiding the buckling of the pipe.

We offer manual (up to 14") or hydraulic mandrels with up to two motors in a wide range of sizes which can be easily fed through the dedicated PTO outlet of the bending machine.

Bending sets

EPE bending sets are manufactured with high quality steel, welded and reinforced in high stress areas for maximum strength and resistance. The internal surface is finished with tooling machines to guarantee the required accuracy and can also be proposed with Polyurethane lining upon request. Bending sets are compatible with bending machines by other manufacturer.



ENGINE

Caterpillar or **Yanmar** diesel engines are selected as the best fitting solution according to the size of the equipment. All of them include integrated filtration system, liquid cooling and self-stretching fan towing seals.



OPERATOR'S PLATFORM

The position of the control platform makes EPE bending machine unique in terms of operating comfort and guarantees maximum visibility and low noise levels to the operator. Closed cabine can be proposed on request.

BENDING DATA

Maximum thickness bended in function of steel type - All data are expressed for *inch/mm*

Pipe Size	X52	X60	X70	X80	X100	Radius (feet/meter)	Max.Degree*
22/559	2/50.80	2/50.80	2/50.80	2/50.80	2/50.80	72/21.95	21.6
24/610	2/50.80	2/50.80	2/50.80	2/50.80	2/50.80	76/23.16	20.3
26/660	2/50.80	2/50.80	2/50.80	2/50.80	2/50.80	82/24.99	18.9
28/711	2/50.80	2/50.80	2/50.80	2/50.80	1.75/44.5	88/26.82	17.6
30/762	2/50.80	2/50.80	2/50.80	1.94/49.2	1.47/37.3	95/28.96	16.2
32/813	2/50.80	2/50.80	1.90/48.3	1.63/41.3	1.25/31.8	98/29.87	15.6
34/864	2/50.80	1.94/49.2	1.63/41.3	1.40/35.6	1.09/27.6	104/31.70	14.8
36/914	2/50.80	1.70/43.2	1.42/36.1	1.22/31.0	0.96/24.4	115/35.05	13.5

* per 40 feet/12 meter joint



OPTIONS

- **Bend Angle Measurement Device:** consists of three components: two of them placed at both pipe ends and the remote control is hold by the operator. Working temperature -40°C to 50°C. Device precision 1/50 grades.
- **Integrated Closed Cabin:** Upon request the bending machine can be equipped with a heated/conditioned cabin for operator.

DIMENSIONS AND WEIGHTS

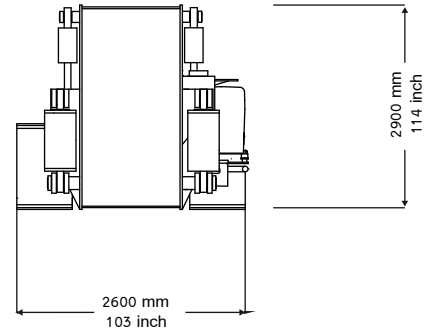
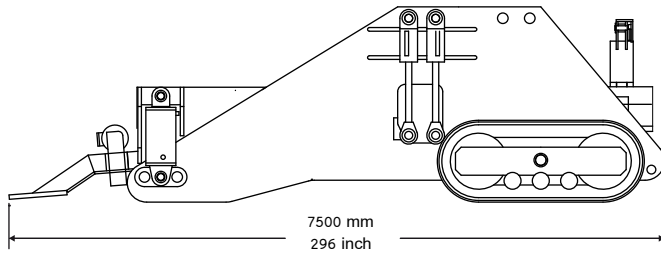

DIMENSIONS

Overall length	7500 mm
Width	2600 mm
Height over exhaust	2900 mm

SHIPPING DIMENSIONS

Overall length	7500 mm
Width	2600 mm
Height over exhaust	2900 mm

WEIGHTS

Operating weight	21000 kg	46297 lbs
------------------	----------	-----------



EURO PIPELINE EQUIPMENT SPA

Strada Provinciale 6 bis
Località Cascine Draghi
29013 Carpaneto Piacentino (PC)
ITALY

Registered Office

via Pontaccio 8
20121 Milan
ITALY

Telephone +39 0523 852064

info@europipeline-equipment.com

www.europipeline-equipment.com



PIPELINE SOLUTIONS