



PERFORMER

700 Pipelayers



Max Lift Capacity 75.000 kg
Hydraulic Hard Track Frame Disassembly
Bosch-Rexroth Components
Caterpillar Engine

PIPELINE SOLUTIONS



BASIC DATA

ENGINE

Model	Caterpillar C9 ACERT
Net Flywheel power	350 HP/257 kW
Governed speed	2100 rpm
Displacement	8,8 lt - 6 in line cylinder

TRANSMISSION

Type	Hydrostatic closed circuit
Brakes	2 integrated negative control
Final drives	Epicycloidal oil soaked
Maximum speed	1 speed - 2.28 km/h 2 speed - 5.25 km/h

CONTROLS

Type	Hydrostatic Closed Circuit
Safety	Emergency shut-off
TSS System	Twin steering system to provide with other two levers, to drive the track independently in order to guarantee small and precise movements.

FLUID CAPACITIES

Fuel tank	350 lt
Hydraulic System circuit	400 lt
Cooling system	42 lt
Engine oil	34 lt
Final drive each	30+30 lt



HYDRAULIC SYSTEM

Main Pumps	3 independent variable Bosch-Rexroth pumps
Maximum capacity	2x367 lt/min 1x290 lt/min
Maximum operating pressure	420 bar
Service pumps	1 tandem gear pump

HARD TRACK FRAME

Dismountable, sealed and lubricated chain D9H type	
Number of bottom roller	9+9
Number of carrying rollers	2+2
Gauge	2,6 m
Length of track on the ground	4,25 m
Standard shoes width	800 mm
Ground contact area	60000 cm ²

ELECTRIC SYSTEM

Operating voltage	24 V
Maintenance free supplied batteries	2
Capacity (total)	170 Ah
Starter capacity	7,5 KW
Alternator	60 A



PIPELAYING EQUIPMENT

HYDRAULIC WINCHES (OPTION)

Type	Hydraulic controlled drum reversible Driven by variable flow hydraulic pump and control valve block in open circuit
Final drive	Compact hydrostatic drive unit, three-stage planetary gear

HOOK AND BOOM WINCHES

Drum diameter	400 mm
Flange diameter	590 mm
Drum length	363 mm
Capacity	136 m
Wire rope installed	120 m
Hook speed	0-16 m/min

BOOM SPECIFICATIONS

Type	7,0 m welded box square section
Diameter wire rope	19 mm
Min. breaking strength rope	323 KN
Part load line	8
Part boom line	6

ADJUSTABLE COUNTERWEIGHTS

QD-CS	Quick-disconnected counterweight system for fast disassembly of the counterweight pack.
Removable Counterweight	12 leaves 583 Kg
Total weight extendable	7000 Kg

WINCH SPECIFICATIONS

MAIN PUMP

Type	Bosch-Rexroth axial piston variable displacement pump
------	--

VALVES

Type	Bosch load-sensing mobile control block proportional directional valves
Working pressure	320 bar

CONTROL

Type	Pilot units for remote control of winch motors
------	---

SERVICE PUMP

Type	Gear pump
Max capacity	10 lt/min
Working pressure	30 bar

OPTIONAL

- Closed cabin
- Air conditioning
- Rear Winch
- Winterized Version
- Proximity Sensor

FEATURES

- CE Approval Design
- ROPS/FOPS for best view of the top of the boom and of the load

SAFETY

- Anti - Tipping System
- Electronic Boom Kick-out
- Free Fall
- Load Monitoring System

DIMENSIONS AND WEIGHTS

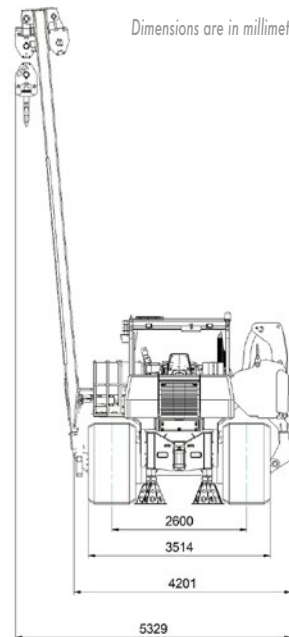
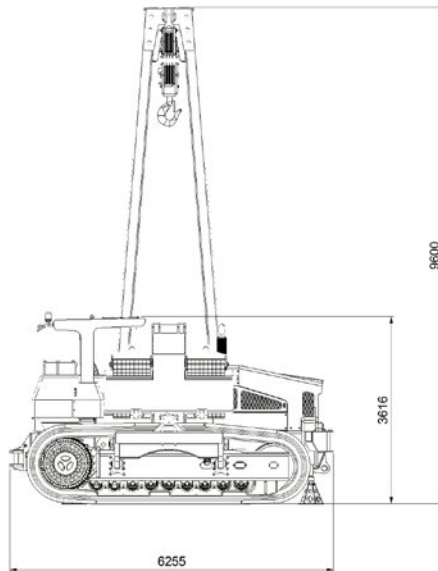

OPERATIONAL WEIGHT 50,000 KG



EURO PIPELINE EQUIPMENT SPA

Strada Provinciale 6 bis
Località Cascine Draghi
29013 Carpaneto Piacentino (PC)
ITALY

Registered Office

via Pontaccio 8
20121 Milan
ITALY

Telephone +39 0523 852064

info@europipeline-equipment.com

www.europipeline-equipment.com



PIPELINE SOLUTIONS